

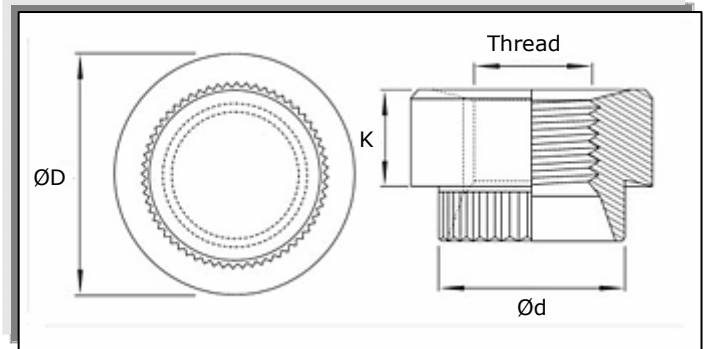

Cambridge Engineering Services Ltd

Tel 01767 699766 Fax 01767 692058

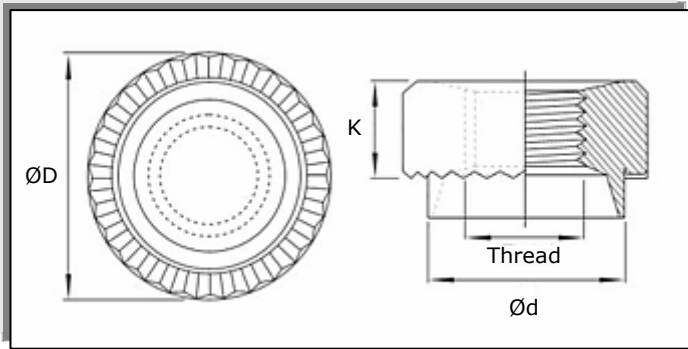

Data sheet for Metric Round Rivet Bushes

Thread Pitch	Sheet Thickness	ØD +/- 0.13	K +/- 0.13	Ød +0.00 -0.13	Hole Size +0.01 -0.00
M2.5 x 0.45 *	20-10 SWG 1.0-3.0mm	7.92	3.17	5.54	5.54
M3 x 0.5	20-10 SWG 1.0-3.0mm	7.92	3.17	5.54	5.54
M3.5 x 0.6 *	20-10 SWG 1.0-3.0mm	9.52	3.17	6.73	6.73
M4 x 0.7	20-10 SWG 1.0-3.0mm	11.10	3.81	6.73	6.73
M5 x 0.8	20-10 SWG 1.0-3.0mm	12.20	5.08	7.92	7.92
M6 x 1.0	20-10 SWG 1.0-3.0mm	12.70	15.87	9.52	9.52
M8 x 1.25	20-10 SWG 1.0-3.0mm	15.87	5.50	12.70	12.70
M10 x 1.5	20-10 SWG 1.0-3.0mm	19.05	7.62	15.87	15.87
M12x 1.75*	20-10 SWG 1.0-3.0mm	25.40	10.16	19.05	19.05

* Made to order

Installation Guide

Finishes

Bright Zinc / Clear Passivate,
Zinc / Yellow Chromate Passivation

Material

Carbon Steel, Stainless Steel
Aluminium (to order), Brass (to order, serrated spigot only)

